

Model 55M-500 Mixer & Carburetor Changes

The Model 55M-500 Mixer (and Carburetors utilizing the Mixer) will receive a new body incorporating the following design changes:

- A new Idle Screw, adjustable using a 4mm hex wrench.
- A new Power Valve, adjustable with a 6mm hex wrench.

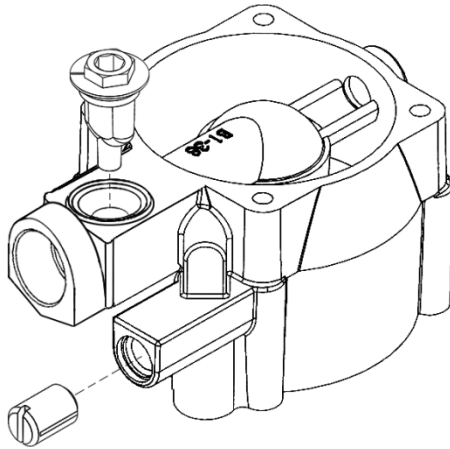

Above: Current Body with the Power Valve adjusted from the top

Right: New Model 55M-500 Body with the new Idle Screw and Power Valve, now adjusted from the bottom (shown with air horn and hardware).

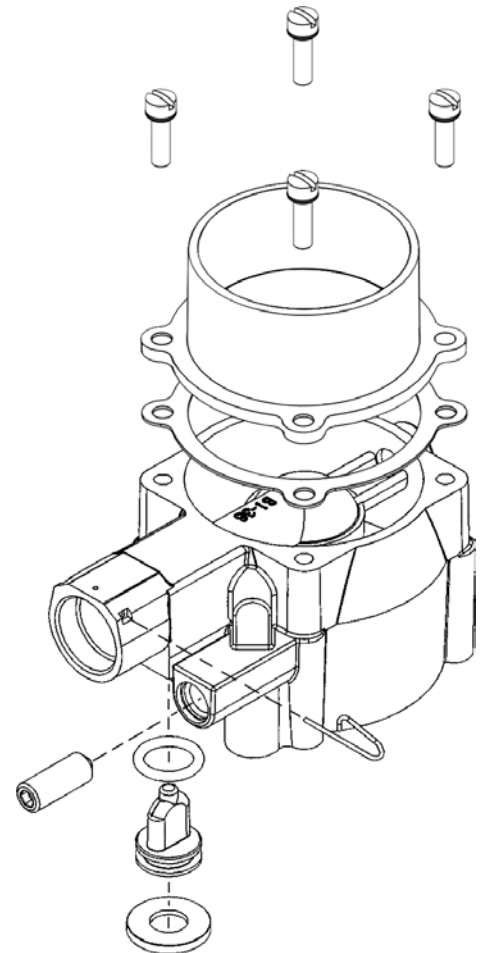

The flow, performance characteristics and most external dimensions remain unchanged. Optional expansion plugs are available to satisfy regulatory tamper resistance requirements.

Right: An optional O-ring port fitting fuel inlet will be available with Mixers that utilize body part number AB1-51156-007.

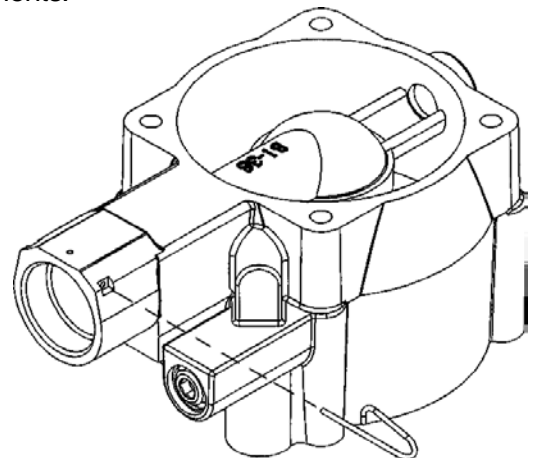

The release of the new designs is scheduled for Fall of 2010.